

# DEVAR Inc.

706 Bostwick Avenue, Bridgeport, CT 06605

TEL: 203-368-6751 FAX: 203-368-3747

1-800-566-6822 www.devarinc.com

## Model 18-811

2 Wire  
Thermocouple or mV  
Transmitter





TABLE OF CONTENTS

PAGE OR DWG. NO.

1 - General Description	1
2 - Specifications	2
3 - Installation	4

LIST OF ILLUSTRATIONS

Typical Wiring (FIG. 3.1)	4
General Dimensions of 18-811 (FIG. 3.2)	5
General Dimensions of M31 Bracket (FIG. 3.3)	5
SnapTrack Mounting Rail (FIG 3.4)	6
Assembly of the 18-811 Transmitter into the SnapTrack Mounting Rail (FIG 3.5)	6
Assembly of the 18-811 Transmitter inside a Connection Head (FIG 3.6)	7
Assembly of the 18-811 Transmitter inside a Junction Box (FIG 3.7)	7

## SECTION I

### GENERAL DESCRIPTION

- 1.1 The 18-811 two wire transmitter receives signals from thermocouple or millivolt sources and provides an output current of 4 to 20 mA proportional to the millivolt input. It is designed to connect with only two copper wire leads that will supply the voltage to operate the transmitter from a power supply, and also carry the output current. The output current is then used for recording, computing, or controlling.
- 1.2 The 18-811 is a miniaturized transmitter designed to fit inside a thermocouple head where the spacing between the mounting holes is 1.281 inches. For instance, it can be mounted inside the OMEGA Engineering thermocouple head type NB1 which is their standard thermocouple head. The advantage of putting the transmitter inside a thermocouple head is that the thermocouple extension wires are replaced by two copper wires that not only carry the temperature signal but also the voltage to operate the transmitter. Also, if the spacing between the mounting holes for a thermocouple head is other than 1.281 inches, the 18-811 can still be mounted inside the head using an adapter plate.
- 1.3 The unit has reverse supply polarity protection, and will operate with a wide range of supply voltages (11 to 44 VDC). It has an input break protection circuit that allows the output current to be programmed to go upscale or downscale when a thermocouple wire opens.
- 1.4 The 18-811 is protected from Radio Frequency Interferences (RFI) and Electro Magnetic Interferences (EMI). It also is provided with a current monitor terminal where the output current can be measured without interrupting the power loop. The 18-811 does not provide isolation between the input and current output. For isolated models refer to DEVAR Model 18-215A.

## SECTION II

### SPECIFICATIONS

#### 2.1 General

Size	1.75 inch O.D. by 1.125 inch height Including wiring terminals
Power Requirements	11 to 44 VDC at power terminals
Accuracy	0.1% of span (Includes combined effects of hysteresis, repeatability, and linearity referred to mV input)
Ambient Temperature	-25°C to +85°C
Thermal Zero Shift	< 0.01%/°F of span (>5 mV span) < 0.02%/°F of span (2-5 mV span)
Thermal Span Shift	< 0.01%/°F of span
Weight	1.5 oz.
RFI Resistance	Rated Class 3-C: 0.25% of span per SAMA PMC 33.1-1978 (15 V/meter field strength, 440 to 450 MHz frequency band)

#### 2.2 Input

Sensor	All types of thermocouples and mV sources
Input Span	2 mV to 100 mV
Input break protection	Upscale, standard with TC inputs None, standard with mV inputs Downscale, if specified
Input Source Current	100 nA, upscale 50 nA, downscale 2.8 nA (max.), no break protection

### 2.3

#### Output

Current Output	4 to 20 mA
Current Output Limits	2.5 to 28 mA, typical
Load Resistance	$R_L (\text{Max}) = (V_{\text{supply}} - 11) / 20$ (K Ohms)
Load Resistance Effect	0.05% of span per 300 Ohm change
Power Supply Effect	0.01% of output span per Volt

### 2.4

#### Options

-M31S	3" SnapTrack (holds 2 units)
-ST	3" SnapTrack (specify length)
-M31D	DIN Rail Mounting Hardware
-DR	DIN Rail (specify length)
-CHN	Nylon Connection Head
-CHA	Aluminum Connection Head, screw top
-CHAS	Aluminum Connection Head, snap top
-CHX	Explosion Proof Connection Head
-NE4	NEMA 4 Enclosure (3" × 3" × 5")
-M37A	Explosion Proof Housing
-M37I	Explosion Proof Housing with Window
-M36	2" Pipe Mount (for -M37)
-TCSF - (length)	Spring Loaded TC (specify length)
-TCBF - (length)	Brazed Loaded TC (specify length)
-E88	Voltage Divider
-IS	Intrinsically Safe

### SECTION III

#### INSTALLATION

- 3.1 The 18-811 mV/TC transmitter can be surface mounted, or installed into a SnapTrack mounting rail using a M31 bracket. Because of the small size, 12 units will fit onto each foot length of a 3" wide SnapTrack. In addition, the 18-811 transmitter can be mounted inside a thermocouple head or a junction box.
- 3.2 Connect appropriate DC power source in series with load to (+) and (-) power terminals. Note, the load may be connected to either the (+) or (-) power lead. Also connect the thermocouple or millivolt source to (+) and (-) input terminals.

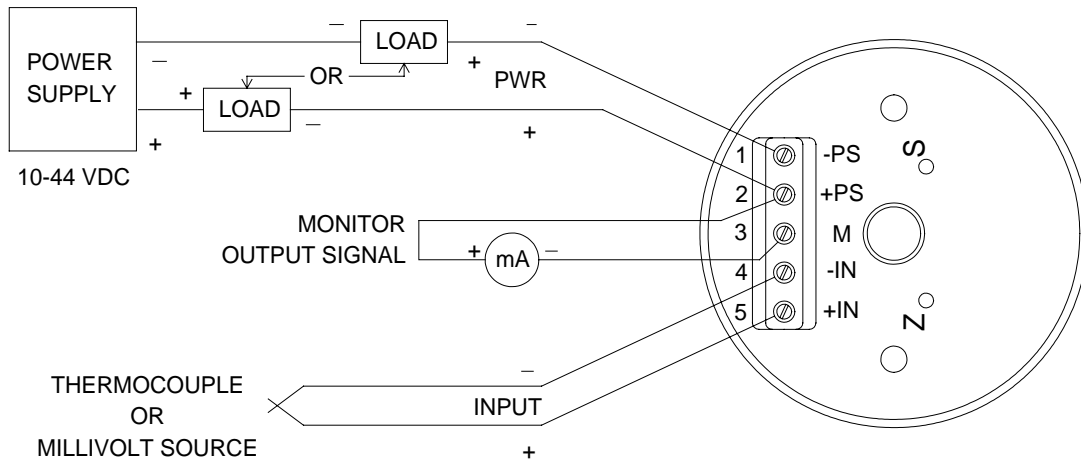

FIG. 3.1 - Typical Wiring

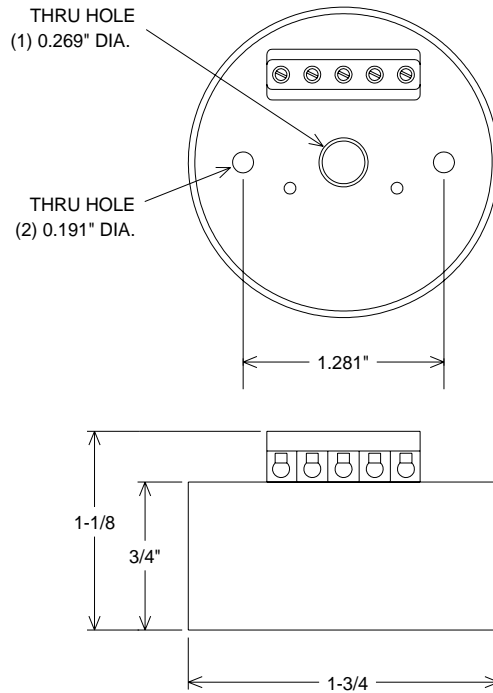

FIG. 3.2 - General Dimensions of 18-811

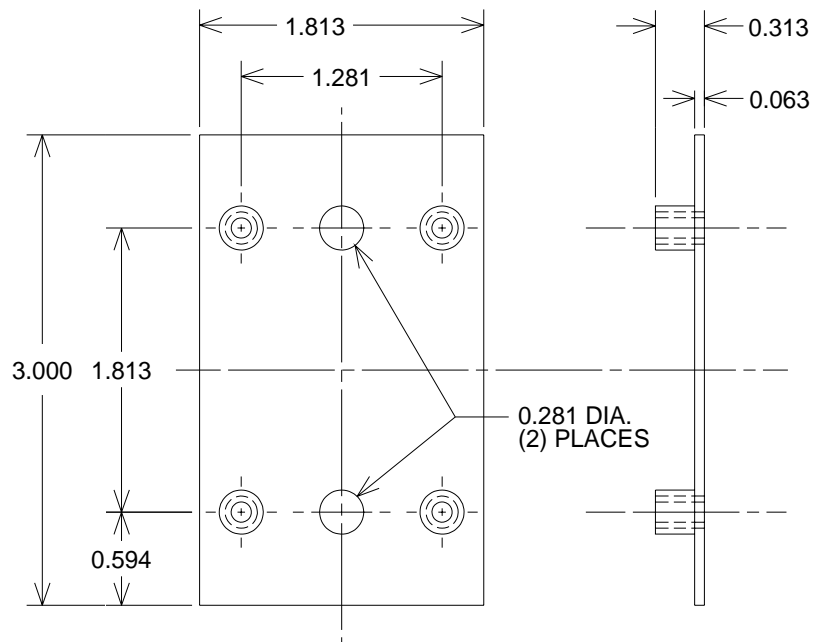

FIG. 3.3 - General Dimensions of M31 Bracket

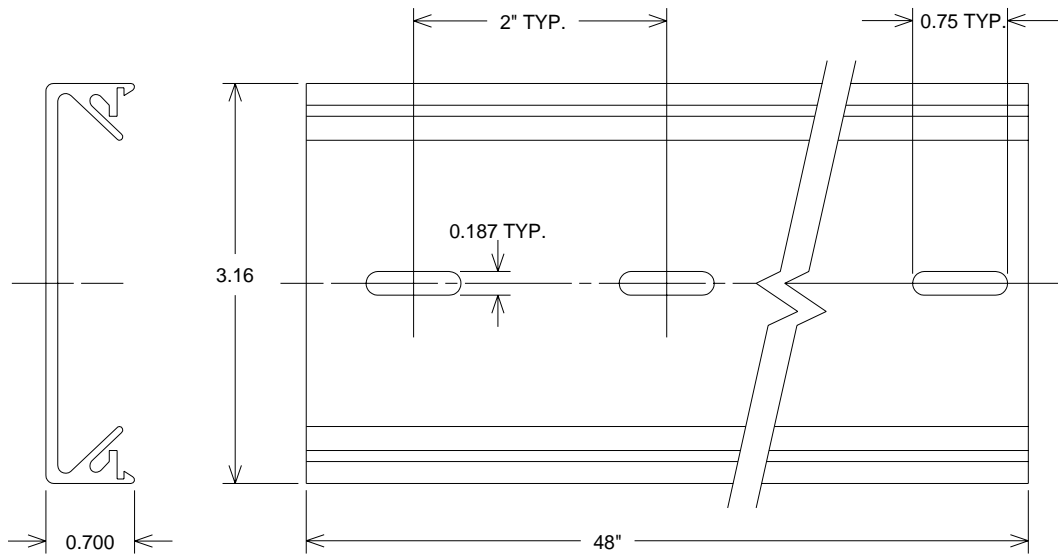

FIG. 3.4 - General Dimensions of SnapTrack Mounting Rail

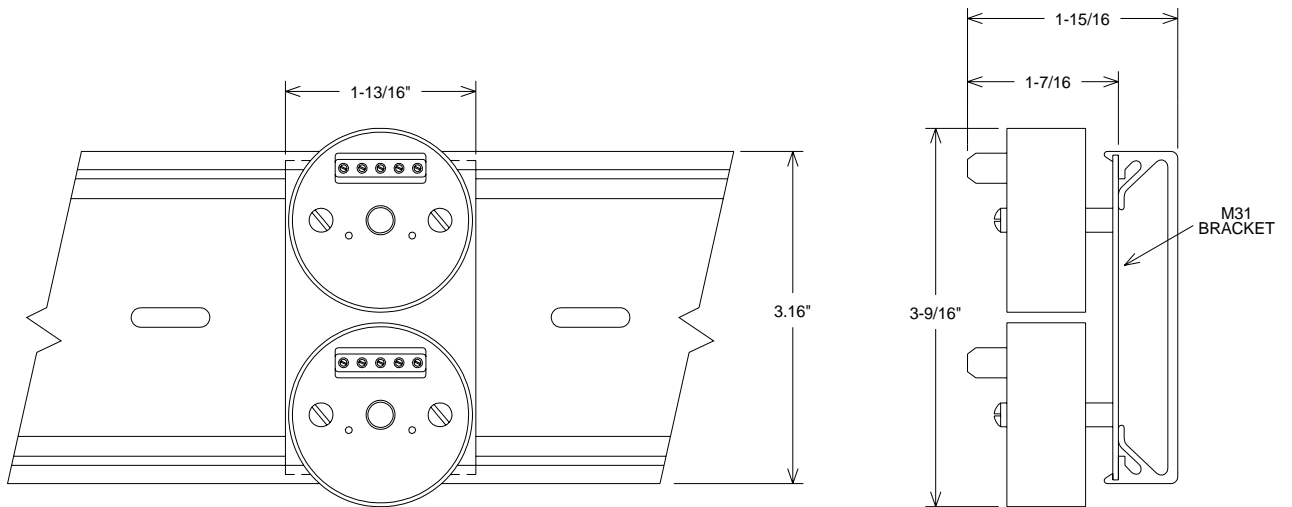

FIG. 3.5 - Assembly of the 18-811 Transmitter into the SnapTrack Mounting Rail

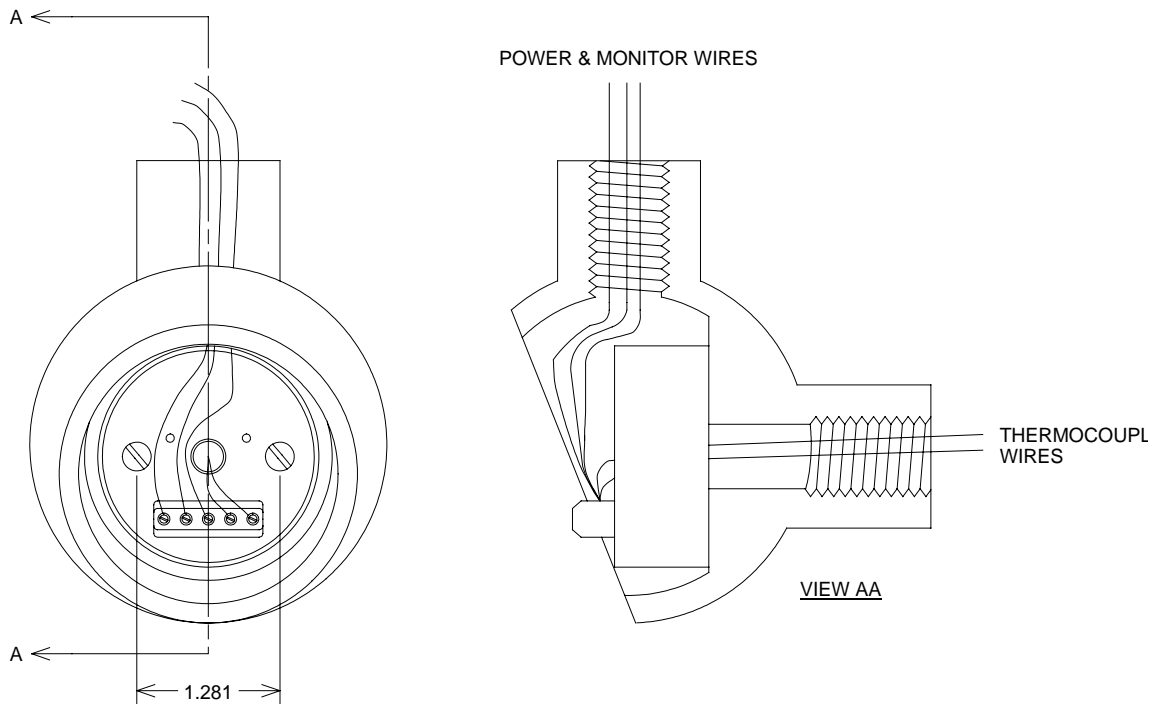

FIG. 3.6 - Assembly of the 18-811 Transmitter inside a thermocouple head

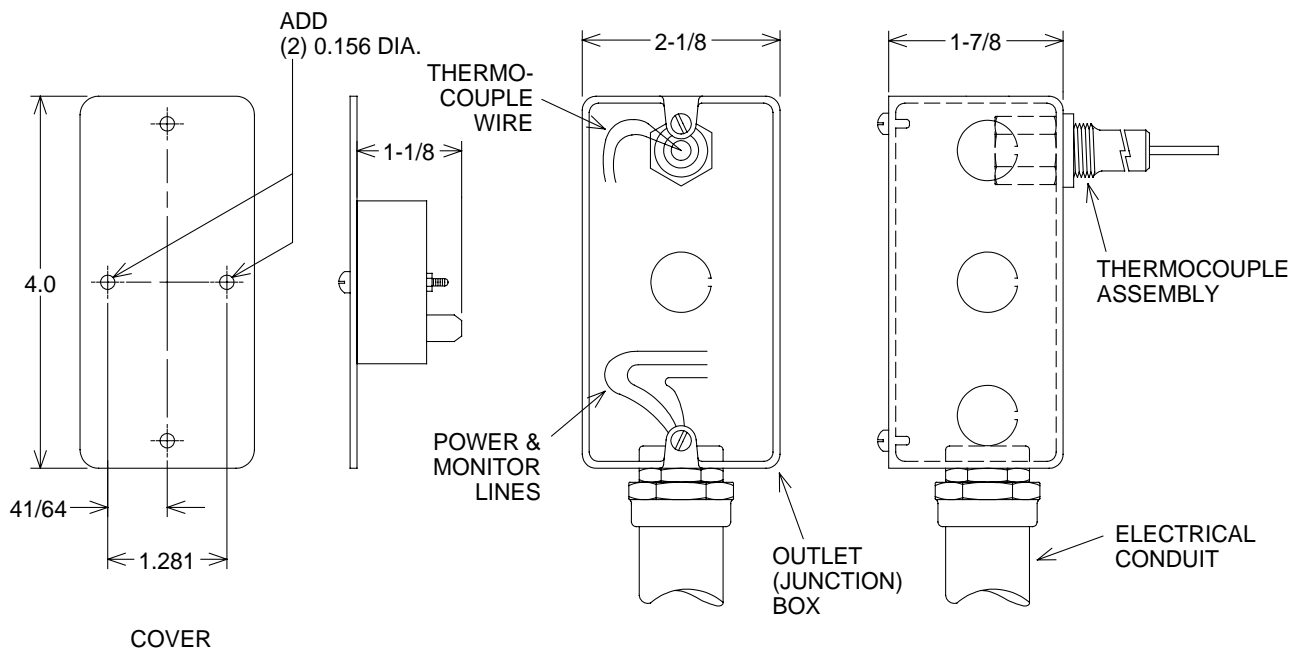

FIG. 3.7 - Assembly of the 18-811 Transmitter inside a junction box